



aerospace
climate control
electromechanical
filtration
fluid & gas handling
hydraulics
pneumatics
process control
sealing & shielding



LF 3600 Nickel-Plated Brass Instant Fittings

One fitting for all industrial applications!



ENGINEERING YOUR SUCCESS.

NEW AND IMPROVED



Welding

Tooling

Painting lines

Meat processing

Automotive process



Food process

Coffee machines

Medical equipment

Printing machines

Enhanced technical performance fittings.

- > Now resist up to 150°C at 30 bar!
- > Excellent resistance to high pressure and vacuum.
- > An HACCP*-improved product with particularly long threads to resist shocks, stress and vibrations.
- > Spring collet gripping for long-term resistance.
- > Excellent resistance to abrasion and corrosion due to high phosphorus chemical nickel plating.
- > Full flow passage, minimal pressure drop.

Suitable for many specialized applications.

- > Can even be used in the food industry.
- > Materials conform to FDA standards and to European Regulation 1935/2004/EC.

Time-saving and easy-to install.

- > Instant manual connection and disconnection.

Extremely compact.

- > Overall dimensions are small.
- > Interconnectability allows for specific combinations.

Unit quality control and dating and traceability of products.

- > Guarantees quality.

The widest range on the market.

- > More than 250 part numbers.

* HACCP : Hazard Analysis Critical Control Point

> Technical Specifications

high phosphorus chemical nickel-plated brass body

FKM (FPPM) fluoroelastomer 'O' ring
USDA H1 grease

high phosphorus chemical nickel-plated brass collet

high phosphorus chemical nickel-plated brass washer

high phosphorus chemical nickel-plated brass sub-base

Suitable Fluid	All fluids and gases compatible with the materials of the fitting. Examples: compressed air, grease, water, food...
Working Pressure	30 bar (limited to 20 bar for compact swivel elbows 3699, 3609)
Working Temperature	-20°C to +150°C
Vacuum	99% (755mmHg)

> Maximum tightening torque for LF 3600, BSPP and metric threads

	Thread	DaN.m
Maximum tightening torque for LF 3600, BSPP and metric threads	M5x0,8	0,16 DaN.m
	G1/8	0,8 DaN.m
	G1/4	1,2 DaN.m
	G3/8	3 DaN.m
	G1/2	3,5 DaN.m

> Tubing

- Polyurethane tubing
- Polyamide tubing
- Polyethylene and fluoropolymer FEP tubing
- Anti-spark tubing

> How to recognize the new generation

The note 150° is mentioned on the packaging label.

OLD NEW

The seal is dark brown.

The letter P is written on the collet.

Caution : for use at +150°C - 30 bar, it is the user's responsibility to check that the new generation of LF 3600 is indeed used.

> Regulations

The LF 3600 instant fittings conform to the following standards:



All materials in contact with food are in compliance with the American Food and Drug Administration.



All materials in contact with food are in compliance with the European Regulation 1935/2004/EC (minimum flow 0,02 l/h)



USDA H1 grease



Reduction of Hazardous Substances – 002/95/CE. All products shown in this catalogue are RoHS-certified

Other compliances:

- FMVSS 302: flammability of materials used in the occupant compartments of motor vehicles
- DIN 73378: polyamide tubing for use in motor vehicles
- UL 94 VO and UL 94 HB: certification of non-combustibility of materials
- ASTM B733 - 04: for autocatalytic (electroless) nickel-phosphorus coatings on metal
- European Directive ATEX: for devices used in potentially explosive atmospheres

> Our instant fittings are guaranteed silicone-free.

Threaded Fittings

3675 Male stud, BSPT thread

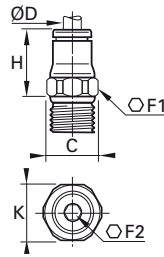

ØD	C		F1	F2	H	K	
4	R1/8	3675 04 10	10	3	15	11	0,009
4	R1/4	3675 04 13	14	3	15	15	0,018
6	R1/8	3675 06 10	13	4	17	14	0,014
6	R1/4	3675 06 13	14	4	17	15	0,019
8	R1/8	3675 08 10	15	5	19	16	0,016
8	R1/4	3675 08 13	15	6	18	16	0,020
8	R3/8	3675 08 17	17	6	18,5	18,5	0,031
10	R1/4	3675 10 13	18	7	23	19,5	0,027
10	R3/8	3675 10 17	18	8	22,5	19,5	0,035
10	R1/2	3675 10 21	22	8	22,5	24	0,057
12	R1/4	3675 12 13	20	7	25,5	22	0,037
12	R3/8	3675 12 17	20	9	24	22	0,035
12	R1/2	3675 12 21	22	10	23	24	0,051
14	R3/8	3675 14 17	22	9	27	24	0,055
14	R1/2	3675 14 21	24	11	26	26	0,063

3601 Male stud BSPP and metric thread

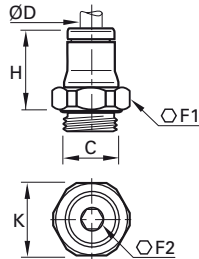

ØD	C		F1	F2	H	K	
4	M5x0.8	3601 04 19	10	2,5	15,5	11	0,006
4	G1/8	3601 04 10	13	3	14,5	14	0,009
4	M6x1	3601 04 52	10	3	16	11	0,007
4	G1/4	3601 04 13	16	3	14,5	17,5	0,015
4	M8x1	3601 04 56	11	3	14,5	12	0,007
6	M5x0.8	3601 06 19	13	2,5	19	14	0,010
6	G1/8	3601 06 10	13	4	17,5	14	0,011
6	M10x1	3601 06 60	13	4	17,5	14	0,010
6	G1/4	3601 06 13	16	4	17	17,5	0,016
8	G1/8	3601 08 10	15	5	20	16	0,015
8	G1/4	3601 08 13	16	6	18	17,5	0,014
8	G3/8	3601 08 17	20	6	19	22	0,028
10	G1/4	3601 10 13	18	7	25	19,5	0,026
10	G3/8	3601 10 17	20	8	22,5	22	0,029
10	G1/2	3601 10 21	24	8	22,5	26	0,045
12	G1/4	3601 12 13	20	7	26,5	22	0,032
12	G3/8	3601 12 17	20	9	26	22	0,037
12	G1/2	3601 12 21	24	10	23,5	26	0,047
14	G3/8	3601 14 17	22	9	28	24	0,039
14	G1/2	3601 14 21	24	11	26,5	26	0,050

3681 Male stud, metric thread

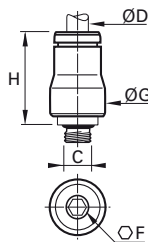

ØD	C		F	G	H	
4	M5x0.8	3681 04 19	2,5	10	16	0,005

3614 Female stud, BSPP and metric thread

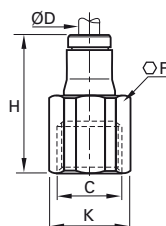

ØD	C		F	H	K	
4	M5x0.8	3614 04 19	10	22	11	0,011
4	G1/8	3614 04 10	14	25	15	0,016
4	G1/4	3614 04 13	17	29	18,5	0,026
6	G1/8	3614 06 10	14	27,5	15	0,019
6	G1/4	3614 06 13	17	31,5	18,5	0,029
8	G1/8	3614 08 10	15	28,5	16	0,022
8	G1/4	3614 08 13	17	32,5	18,5	0,032
10	G3/8	3614 10 17	22	38	24	0,053
12	G3/8	3614 12 17	22	39	24	0,056
12	G1/2	3614 12 21	24	43,5	26	0,063

Threaded Fittings

3621 Male stud standpipe, BSPT thread

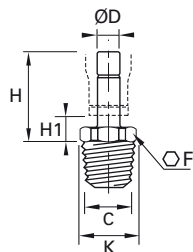

ØD	C		F	H	H1	K	
4	R1/8	3621 04 10	10	21	7	11	0,007
4	R1/4	3621 04 13	14	21	7	15	0,014
6	R1/8	3621 06 10	10	23,5	6,5	11	0,008
6	R1/4	3621 06 13	10	23,5	6,5	15	0,015
8	R1/8	3621 08 10	10	24	6,5	11	0,008
8	R1/4	3621 08 13	14	24	6,5	15	0,016
10	R1/4	3621 10 13	14	22	6,5	15	0,018
10	R3/8	3621 10 17	17	30	7,5	18,5	0,029
12	R3/8	3621 12 17	17	31	7,5	18,5	0,024
12	R1/2	3621 12 21	22	38	7,5	24	0,041
14	R1/2	3621 14 21	22	33	8	24	0,042

3631 Male stud standpipe, BSPP and metric thread

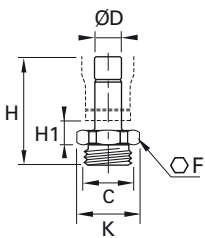

ØD	C		F	H	H1	K	
4	M5x0.8	3631 04 19	13	25,5	7	14	0,003
4	G1/8	3631 04 10	16	26,5	7	17,5	0,007
4	G1/4	3631 04 13	8	25	7,5	8,7	0,011
6	G1/8	3631 06 10	13	28	6,5	14	0,008
6	G1/4	3631 06 13	16	29	6,5	17,5	0,012
8	G1/8	3631 08 10	13	28,5	6,5	14	0,009
8	G1/4	3631 08 13	16	29,5	6,5	17,5	0,013
8	G3/8	3631 08 17	20	30,5	7,5	22	0,021
10	G1/4	3631 10 13	16	34,5	6,5	17,5	0,017
10	G3/8	3631 10 17	20	35,5	7,5	22	0,023
10	G1/2	3631 10 21	24	37	7,5	26	0,029
12	G3/8	3631 12 17	20	36,5	7,5	22	0,021
12	G1/2	3631 12 21	24	38	7,5	26	0,031
14	G1/2	3631 14 21	24	40	8	26	0,031

3609 Male stud elbow, BSPT thread

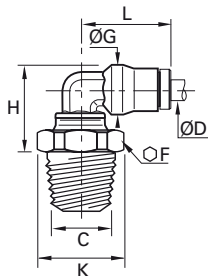

ØD	C		F	G	H	K	L	
4	R1/8	3609 04 10	13	10	15	12	18	0,014
4	R1/4	3609 04 13	14	10	17	15	18	0,020
6	R1/8	3609 06 10	13	12	17,5	12	21,5	0,018
6	R1/4	3609 06 13	14	12	19	15	21,5	0,025
8	R1/8	3609 08 10	13	15	19,5	12	23,5	0,023
8	R1/4	3609 08 13	14	15	21	15	23,5	0,028
8	R3/8	3609 08 17	17	15	21	18,5	23,5	0,034
10	R1/4	3609 10 13	15	17,5	23,5	16	29	0,038
10	R3/8	3609 10 17	17	17,5	25,5	18,5	29	0,042
12	R1/4	3609 12 13	15	19,5	26	16	31	0,052
12	R3/8	3609 12 17	17	19,5	28,5	18,5	31	0,052
12	R1/2	3609 12 21	21	19,5	28,5	23	31	0,070
14	R3/8	3609 14 17	19	21,5	29	21	34	0,066
14	R1/2	3609 14 21	24	21,5	30	26	34	0,076

3699 Male stud elbow, BSPP and metric thread

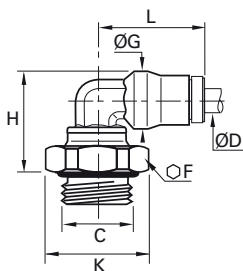

ØD	C		F	G	H	K	L	
4	M5x0.8	3699 04 19	10	10	18	11	18	0,012
4	G1/8	3699 04 10	13	10	17	14	18	0,015
4	M6x1	3699 04 52	10	10	18	11	18	0,012
4	G1/4	3699 04 13	16	10	17,5	17,5	18	0,018
4	M8x1	3699 04 56	11	10	18	12	18	0,013
6	G1/8	3699 06 10	13	12	19	14	21,5	0,018
6	M10x1	3699 06 60	13	12	19	14	21,5	0,018
6	G1/4	3699 06 13	16	12	19,5	17,5	21,5	0,022
8	G1/8	3699 08 10	13	15	20,5	14	23,5	0,023
8	G1/4	3699 08 13	16	15	21,5	17,5	23,5	0,025
8	G3/8	3699 08 17	20	15	21,5	22	23,5	0,033
10	G1/4	3699 10 13	16	17,5	27	17,5	29	0,039
10	G3/8	3699 10 17	20	17,5	25,5	22	29	0,040
12	G1/4	3699 12 13	16	19,5	29,5	17,5	31	0,051
12	G3/8	3699 12 17	20	19,5	28,5	22	31	0,053
12	G1/2	3699 12 21	24	19,5	28,5	26	31	0,060
14	G3/8	3699 14 17	20	21,5	29	22	34	0,060
14	G1/2	3699 14 21	24	21,5	29,5	26	34	0,064

Threaded Fittings

3698 Male stud branch tee, BSPP and metric thread

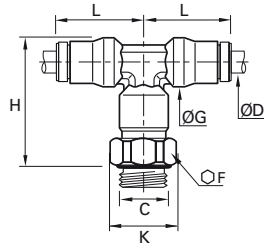

ØD	C		F	G	H	K	L	
4	M5x0.8	3698 04 19	10	10	27,5	11	18	0,020
4	G1/8	3698 04 10	13	10	25,5	14	18	0,021
6	G1/8	3698 06 10	13	12	31	14	21,5	0,033
6	G1/4	3698 06 13	16	12	30,5	17,5	21,5	0,034
8	G1/8	3698 08 10	14	15	33,5	15	23,5	0,041
8	G1/4	3698 08 13	16	15	34	17,5	23,5	0,045
10	G1/4	3698 10 13	18	17,5	42	19,5	29	0,066
12	G3/8	3698 12 17	20	19,5	46	22	31	0,100
14	G1/2	3698 14 21	24	21,5	49	26	34	0,109

3693 Male stud run tee, BSPP and metric thread

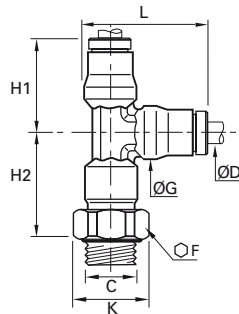

ØD	C		F	G	H1	H2	K	L	
4	M5x0.8	3693 04 19	10	10	18	22,5	11	23	0,020
4	G1/8	3693 04 10	13	10	18	20,5	14	23	0,021
6	G1/8	3693 06 10	13	12	21,5	25	14	28	0,033
6	G1/4	3693 06 13	16	12	21,5	24,5	17,5	28	0,033
8	G1/8	3693 08 10	14	15	23,5	26,5	15	31	0,041
8	G1/4	3693 08 13	16	15	23,5	26,5	17,5	31	0,045
10	G1/4	3693 10 13	18	17,5	29	33	19,5	37,5	0,066
12	G3/8	3693 12 17	20	19,5	31	36,5	22	40,5	0,100
14	G1/2	3693 14 21	24	21,5	34	38,5	26	45	1,129

3618 Single banjo, BSPP and metric thread

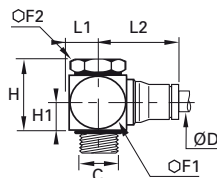

ØD	C		F1	F2	H	H1	L1	L2	
4	M5x0.8	3618 04 19	10	8	14,5	6,5	6	18,5	0,011
4	G1/8	3618 04 10	17	14	23	9,5	10	20,5	0,041
6	M5x0.8	3618 06 19	10	8	15	7	6	22,5	0,014
6	G1/8	3618 06 10	17	14	23	9,5	10	23,5	0,045
6	G1/4	3618 06 13	22	17	22	9	13	25,5	0,068
8	G1/8	3618 08 10	17	14	23	9,5	10	26	0,046
8	G1/4	3618 08 13	22	17	22	9	13	27,5	0,066
10	G3/8	3618 10 13	22	22	33	14	13	32	0,105

3600 Cartridge

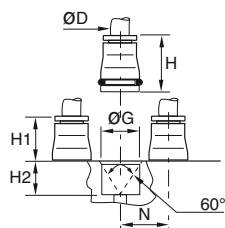

ØD		G	H	H1	H2	N	
4	3600 04 00	10	17	9	8,5	11	0,006
6	3600 06 00	12	19	11	8,5	13,5	0,009
8	3600 08 00	15	21	12,5	8,5	16	0,013
10	3600 10 00	17,5	24,5	14,5	10,5	20	0,020
12	3600 12 00	19,5	25	15	10,5	22,5	0,022
14	3600 14 00	22	28,5	16,5	12	25	0,032

Threaded Fittings

3629 Extended stud elbow, BSPT

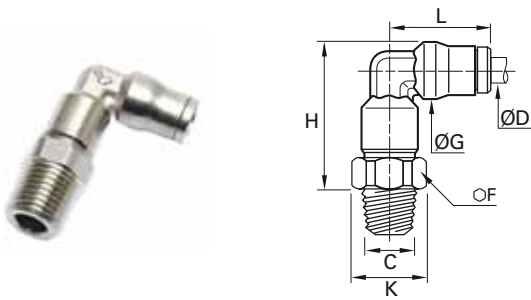

ØD	C		F	G	H	K	L	
4	R1/8	3629 04 10	10	10	24,5	11	18	0,016
6	R1/8	3629 06 10	13	12	29,5	14	21,5	0,025
6	R1/4	3629 06 13	14	12	30,5	15	21,5	0,031
8	R1/8	3629 08 10	14	15	32,5	15	23,5	0,031
8	R1/4	3629 08 13	14	15	34	15	23,5	0,036
10	R1/4	3629 10 13	18	17,5	39	19,5	29	0,053

3669 Extended male stud elbow, BSPP and metric thread

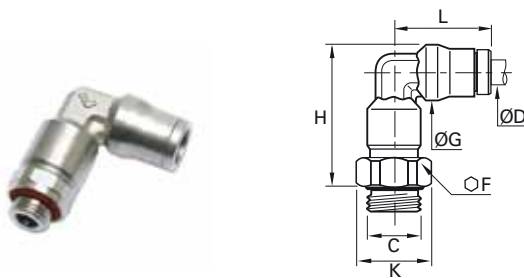

ØD	C		F	G	H	K	L	
4	M5x0.8	3669 04 19	10	10	27,5	11	18	0,015
4	G1/8	3669 04 10	13	10	25,5	14	18	0,017
6	G1/8	3669 06 10	13	12	31	14	18	0,023
6	G1/4	3669 06 13	16	12	30,5	17,5	21,5	0,028
8	G1/8	3669 08 10	14	15	33,5	15	23,5	0,031
8	G1/4	3669 08 13	16	15	34	17,5	23,5	0,036
10	G1/4	3669 10 13	18	17,5	42	19,5	29	0,053
10	G3/8	3669 10 17	20	17,5	41	22	29	0,056
12	G1/4	3669 12 13	20	19,5	47	22	31	0,075
12	G3/8	3669 12 17	20	19,5	46	22	31	0,072
14	G1/2	3669 14 21	24	21,5	49	26	34	0,094

3608 Male stud branch tee, BSPT thread

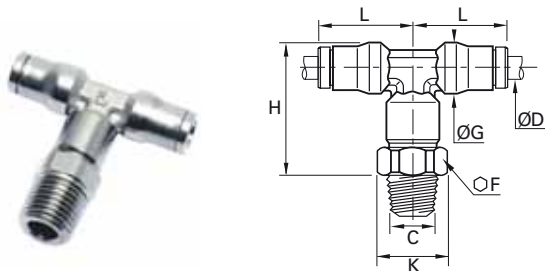

ØD	C		F	G	H	K	L	
4	R1/8	3608 04 10	11	10	24,5	11	18	0,020
6	R1/8	3608 06 10	11	12	29,5	14	21,5	0,031
6	R1/4	3608 06 13	14	12	30,5	15	21,5	0,041
8	R1/8	3608 08 10	11	15	32,5	15	23,5	0,041
8	R1/4	3608 08 13	14	15	34	15	23,5	0,048
10	R1/4	3608 10 13	14	17,5	39	19,5	29	0,070
10	R3/8	3608 10 17	15	17,5	41	19,5	29	0,074
12	R3/8	3608 12 17	17	19,5	46,5	22	31	0,103
14	R1/2	3608 14 21	24	21,5	50,5	24	34	0,142

3603 Male stud run tee, BSPT thread

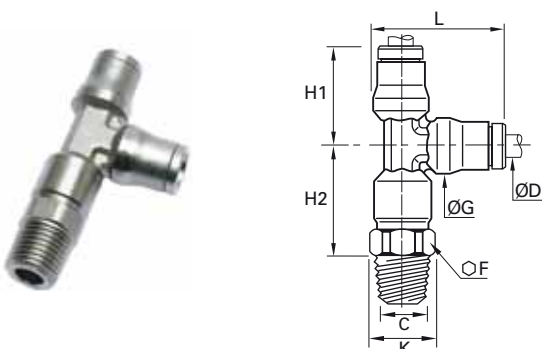

ØD	C		F	G	H1	H2	K	L	
4	R1/8	3603 04 10	10	10	18	19,5	11	23	0,020
6	R1/8	3603 06 10	13	12	21,5	23,5	14	28	0,031
6	R1/4	3603 06 13	14	12	21,5	24,5	15	28	0,041
8	R1/8	3603 08 10	14	15	23,5	25	15	31	0,041
8	R1/4	3603 08 13	14	15	23,5	26,5	15	31	0,048
10	R1/4	3603 10 13	18	17,5	29	30,5	19,5	37,5	0,070
10	R3/8	3603 10 17	18	17,5	29	32,5	19,5	37,5	0,074
12	R3/8	3603 12 17	20	19,5	31	36,5	22	40,5	0,103
14	R1/2	3603 14 21	22	21,5	34	40	24	45	0,142

Bulkhead Connectors and Tube-to-Tube Fittings

3616 Equal bulkhead connector

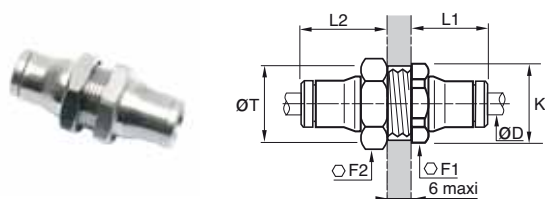

ØD		F1	F2	K	L1	L2	T	
4	3616 04 00	13	14	14	14	20	12,5	0,019
6	3616 06 00	16	17	17,5	17	22	15	0,028
8	3616 08 00	18	19	19,5	18,5	23,5	17	0,036
10	3616 10 00	22	27	24	21,5	26,5	21	0,067
12	3616 12 00	24	24	26	23	27	23	0,068
14	3616 14 00	27	27	29,5	25,5	29,5	25	0,089

3639 Equal bulkhead elbow

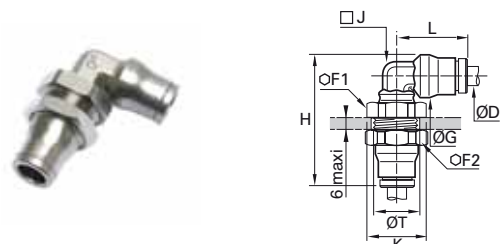

ØD		F1	F2	G	H	J	K	L	T	
4	3639 04 00	13	14	10	35	7	14	18	12,5	0,026
6	3639 06 00	16	17	12	40,5	8	17,5	21,5	15	0,039
8	3639 08 00	18	19	15	44	10	19,5	23,5	17	0,053
10	3639 10 00	22	27	17,5	51	12	24	29	21	0,080
12	3639 12 00	24	24	19,5	55	15	26	31	23	0,091
14	3639 14 00	27	27	21,5	59	16	29,5	34	25	0,114

3636 Female bulkhead connector, BSP thread

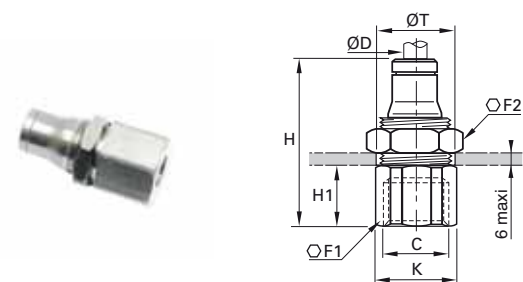

ØD	C		F1	F2	H	H1	K	T	
4	G1/8	3636 04 10	14	14	30,5	11	15	13	0,025
6	G1/8	3636 06 10	17	17	33	11	18,5	15	0,038
6	G1/4	3636 06 13	17	17	37	15	18,5	15	0,033
8	G1/8	3636 08 10	19	19	34	10,5	21	17	0,044
8	G1/4	3636 08 13	19	19	38	14,5	21	17	0,053
10	G3/8	3636 10 17	22	27	42,5	16	24	21	0,089
12	G3/8	3636 12 17	24	24	43	16	26	23	0,103
12	G1/2	3636 12 21	27	24	48,5	21,5	29,5	23	0,123

3606 Equal tube-to-tube connector

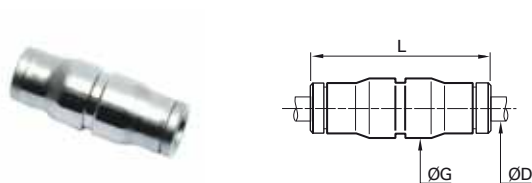

ØD		G	L	
4	3606 04 00	10	30,5	0,010
6	3606 06 00	12	36,5	0,017
8	3606 08 00	15	37,5	0,021
10	3606 10 00	17,5	47,5	0,036
12	3606 12 00	19,5	50	0,046
14	3606 14 00	21,5	52,5	0,052

3602 Equal elbow

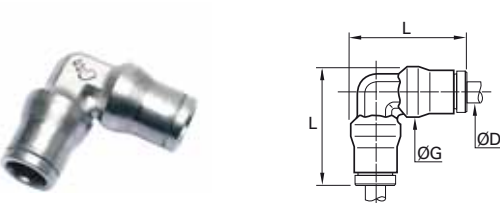

ØD		G	L	
4	3602 04 00	10	23	0,011
6	3602 06 00	12	28	0,017
8	3602 08 00	15	31	0,023
10	3602 10 00	17,5	37,5	0,036
12	3602 12 00	19,5	40,5	0,046
14	3602 14 00	21,5	45	0,058

3604 Equal tee

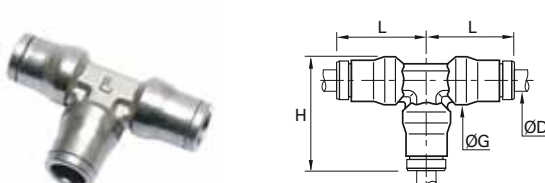

ØD		G	H	L	
4	3604 04 00	10	23	18	0,015
6	3604 06 00	12	28	21,5	0,023
8	3604 08 00	15	31	23,5	0,032
10	3604 10 00	17,5	37,5	29	0,049
12	3604 12 00	19,5	40,5	31	0,065
14	3604 14 00	21,5	45	34	0,078

Plug-in Accessories

3666 Plug-in reducer

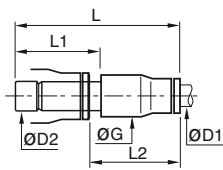

ØD1	ØD2		G	L	L1	L2	
4	6	3666 04 06	10	35	19,5	18	0,008
4	8	3666 04 08	10	35,5	20	18	0,010
6	8	3666 06 08	12	38	20	20,5	0,013
6	10	3666 06 10	12	43,5	25	21	0,015
8	10	3666 08 10	15	44	25	21,5	0,017
8	12	3666 08 12	15	44	26	20,5	0,019
10	12	3666 10 12	17,5	50	26	27	0,028
12	14	3666 12 14	19,5	53	28	28,5	0,039

3620 Double male stem connector

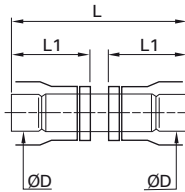

ØD		L	L1	
4	3620 04 00	31	14	0,002
6	3620 06 00	36,5	17	0,005
8	3620 08 00	37,5	17,5	0,007
10	3620 10 00	47,5	22,5	0,010
12	3620 12 00	49,5	23,5	0,014
14	3620 14 00	53	25	0,017

3668 Plug-in increaser

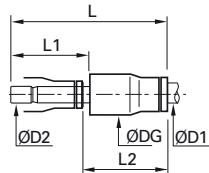

ØD1	ØD2		G	L	L1	L2	
6	4	3668 06 04	12	36	17	21,5	0,010

3622 Plug-in barbed connector

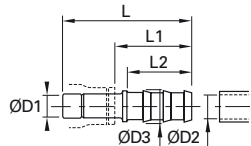

ØD1	ØD2	ØD3		L	L1	L2	
4	3,2	5	3622 04 53	40,5	27	22,5	0,003
4	5	7	3622 04 05	40,5	27	22,5	0,004
6	5	7	3622 06 05	43	27	22,5	0,006
8	6,3	8,3	3622 08 56	42	25	22,5	0,008
8	8	10	3622 08 08	44	27	22,5	0,009
10	6,3	8,3	3622 10 56	47,5	25,5	22,5	0,011
10	8	10	3622 10 08	47,5	25,5	22,5	0,011
12	8	10	3622 12 08	48,5	25,5	22,5	0,013
12	10	12	3622 12 10	48,5	25,5	22,5	0,014
12	12,5	14,5	3622 12 62	57	34	29,5	0,019
14	12,5	14,5	3622 14 62	57,5	33	29,5	0,022
14	14	16	3622 14 14	59,5	35	29,5	0,023

3667 Plug-in metric / imperial adaptor

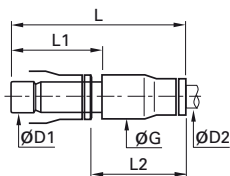

ØD1	ØD2		G	L	L1	L2	
6	1/4	3667 06 56	12,5	38,5	19,5	21	0,013
10	3/8	3667 10 60	17	49,5	25	27	0,027
12	1/2	3667 12 62	20	51	26	27,5	0,033

3626 Blanking plug

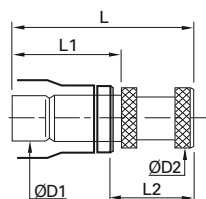

ØD1	ØD2		L	L1	L2	
4	6	3626 04 00	25,5	17	11,5	0,004
6	8	3626 06 00	30,5	19,5	13,5	0,009
8	10	3626 08 00	33	20	16	0,010
10	12	3626 10 00	40	25	18	0,015
12	14	3626 12 00	43	26	20	0,025
14	16	3626 14 00	47	28	22,5	0,029

Nickel-Plated Brass Accessories and Plugs

Working pressure : 60 bar maximum - Working temperature : -40°C to +150°C / Available threads : M5 to 3/4
The accessories are in conformity with RoHS standards.

0912 Equal female stud elbow, BSP parallel and M5

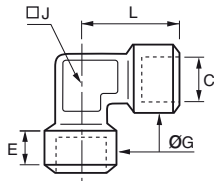

C		E	G	J	L	
M5x0,8	0912 00 19	4	8	9	11	0,006
G1/8	0912 00 10	8	13	10	21	0,020
G1/4	0912 00 13	11	17	13	25,5	0,040
G3/8	0912 00 17	11,5	21	17	28	0,059
G1/2	0912 00 21	14	26	21	33,5	0,100
G3/4	0912 00 27	15	31	27	36,5	0,154

0913-0921 Equal female stud elbow BSP parallel, male BSP taper and M5

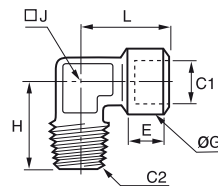

C1	C2		E	G	H	J	L	
M5x08	M5x08	0921 00 19	4	8	11	9	11	0,006
G1/8	R1/8	0913 00 10	8	13	18,5	10	21	0,017
G1/4	R1/4	0913 00 13	11	17	23,5	13	25,5	0,033
G3/8	R3/8	0913 00 17	11,5	21	26	17	28	0,050
G1/2	R1/2	0913 00 21	14	26	31	21	33,5	0,085
G3/4	R3/4	0913 00 27	15	31	35	27	36,5	0,122

0915 Equal female tee, BSP parallel and M5

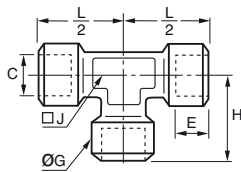

C		E	G	H	J	L/2	
M5x0,8	0915 00 19	4	8	11	9	11	0,009
G1/8	0915 00 10	8	13	21	10	21	0,028
G1/4	0915 00 13	11	17	25,5	13	25,5	0,056
G3/8	0915 00 17	11,5	21	28	17	28	0,083
G1/2	0915 00 21	14	26	33,5	21	33,5	0,139
G3/4	0915 00 27	15	31	36,5	27	36,5	0,215

0916-0923 Male stud branch tee, female BSP parallel, male BSP taper and M5

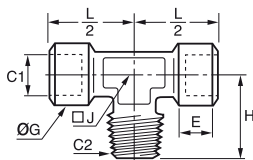

C1	C2		E	G	H	J	L/2	
M5x0,8	M5x0,8	0923 00 19	4	8	11	9	11	0,009
G1/8	R1/8	0916 00 10	8	13	18,5	10	21	0,025
G1/4	R1/4	0916 00 13	11	17	23,5	13	25,5	0,049
G3/8	R3/8	0916 00 17	11,5	21	26	17	28	0,076
G1/2	R1/2	0916 00 21	14	26	31	21	33,5	0,125
G3/4	R3/4	0916 00 27	15	31	36,5	27	36,5	0,187

0911 Equal 'Y', female BSP parallel, male BSP taper

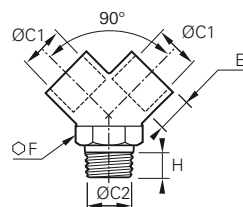

C1	C2		E	F	G	
G1/8	R1/8	0911 00 10	8	13	12	0,022
G1/4	R1/4	0911 00 13	11	17	14	0,039
G3/8	R3/8	0911 00 17	11,5	20	16	0,053
G1/2	R1/2	0911 00 21	14	25	19	0,107

0908 Equal female cross, BSP parallel

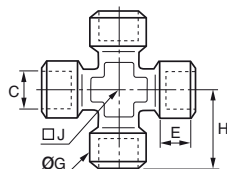

C1		E	G	H	J	
G1/8	0908 00 10	8	13	21	10	0,035
G1/4	0908 00 13	11	17	25,5	13	0,072
G3/8	0908 00 17	11,5	21	28	17	0,103
G1/2	0908 00 21	14	26	33,5	21	0,182

Nickel-Plated Brass Accessories and Plugs

0192 Straight male adaptor, BSP taper to BSP parallel

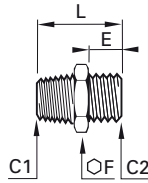

C1	C2		E	F	L	
R1/8	G1/4	0192 10 13	9,5	17	23,5	0,019
R1/4	G1/4	0192 13 13	9,5	17	27,5	0,024
R1/4	G1/2	0192 13 21	27	27	31,5	0,067
R3/8	G1/4	0192 17 13	9,5	17	45	0,025
R3/8	G1/2	0192 17 21	27	27	31,5	0,061
R1/2	G1/2	0192 21 21	27	27	34	0,060

0919 Internal hexagon head, BSP parallel and M5

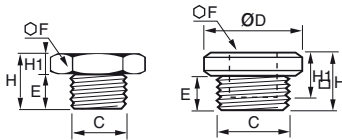

C		ØD	E	F	H	H1	
M5x0,8	0919 00 19	8	4	2,5	7,5	3,5	0,001
G1/8	0919 00 10	15	6	3	10	4	0,008
G1/4	0919 00 13	18	8	6	12	4	0,013
G3/8	0919 00 17	21	9	8	13	4	0,021
G1/2	0919 00 21	25	10	10	14,5	4,5	0,036
G3/4	0919 00 27	-	11	30	17	6	0,044
G1"	0919 00 34	-	13	38	19	6	0,084

3610 Coloured release button covers (anodized aluminium)



ØD			
8	3610 08 02	3610 08 03	0,001
10	3610 10 02	3610 10 03	0,001
12	3610 12 02	3610 12 03	0,001

Associated tubes for LF 3600 applications

Material	Part Number	Diameter (mm)	Pressure (bar)	Temperature (°C)	Maximum pressure at maximum temperature	Application	Advantages
Polyurethane polyester	1025U - 1100U	3 to 14	5 to 14	70	3 to 7	Pneumatics	Flexible and resistant UV resistant with ISO 4892 silicon free, RoHS, halogen free, REACH
Polyurethane polyéther	1025U .. R - 1100U ..R	4 to 14	8 to 14	70	3 to 7	Food process	FDA, CE (minimum flow) UV resistant with ISO 4892 silicon free, RoHS, halogen free REACH
Semi-rigid polyamide	1025P - 1100P	3 to 16	12 to 55	80	12 to 25	Pneumatics	UV resistant with ISO 4892, silicon free, RoHS, halogen free REACH
Rigid polyamide	1025L	4 to 10	32 to 58	80	15 to 28	Pneumatics and lubrication systems	High pressures, silicon free, RoHS, halogen free, REACH
Advanced PE	1025Y - 1100Y	4 to 12	11 to 16	95	3	Food process	FDA, CE, NSP51, 61, 42/58 CE 2002/72 EC Silicon Free, RoHS, Halogen Free, REACH
FEP	1005T - 1025T	4 to 12	10 to 22	150	1 to 6	Food process	FDA, UL94VO Silicon Free, RoHS, REACH
Antistatic Polyurethane	1100U..A01	3 to 12	8 to 14	70	3 to 7	Car industry - Electronics	ATEX, resistivity (103 to 106 ohm) silicon free, RoHS, REACH
Anti-spark Single layer polyurethane	1025U..K - 1100U..K	4 to 12	10 to 14	70	6 to 8	Car industry	UL94VO silicon free, RoHS, REACH
Anti-spark polyamide with PVC coating	1025P..V -1100P..V	6 to 12	15 to 36	80	7 to 18	Car industry	UL94VO, resistance to high pressures, Silicon Free, RoHS

Parker Legris Connectic offers a comprehensive range of instant fittings and tubes; please consult our general catalogue or visit www.legris.com or www.parkerconnectic.com.

Parker Worldwide

Europe, Middle East, Africa

AE – United Arab Emirates,
Dubai

Tel: +971 4 8127100
parker.me@parker.com

AT – Austria, Wiener Neustadt
Tel: +43 (0)2622 23501-0
parker.austria@parker.com

AT – Eastern Europe, Wiener
Neustadt
Tel: +43 (0)2622 23501 900
parker.easteurope@parker.com

AZ – Azerbaijan, Baku
Tel: +994 50 2233 458
parker.azerbaijan@parker.com

BE/LU – Belgium, Nivelles
Tel: +32 (0)67 280 900
parker.belgium@parker.com

BY – Belarus, Minsk
Tel: +375 17 209 9399
parker.belarus@parker.com

CH – Switzerland, Etoy
Tel: +41 (0)21 821 87 00
parker.switzerland@parker.com

CZ – Czech Republic, Klecany
Tel: +420 284 083 111
parker.czechrepublic@parker.com

DE – Germany, Kaarst
Tel: +49 (0)2131 4016 0
parker.germany@parker.com

DK – Denmark, Ballerup
Tel: +45 43 56 04 00
parker.denmark@parker.com

ES – Spain, Madrid
Tel: +34 902 330 001
parker.spain@parker.com

FI – Finland, Vantaa
Tel: +358 (0)20 753 2500
parker.finland@parker.com

FR – France, Contamine s/Arve
Tel: +33 (0)4 50 25 80 25
parker.france@parker.com

GR – Greece, Athens
Tel: +30 210 933 6450
parker.greece@parker.com

HU – Hungary, Budapest
Tel: +36 1 220 4155
parker.hungary@parker.com

IE – Ireland, Dublin
Tel: +353 (0)1 466 6370
parker.ireland@parker.com

IT – Italy, Corsico (MI)
Tel: +39 02 45 19 21
parker.italy@parker.com

KZ – Kazakhstan, Almaty
Tel: +7 7272 505 800
parker.easteurope@parker.com

NL – The Netherlands, Oldenzaal
Tel: +31 (0)541 585 000
parker.nl@parker.com

NO – Norway, Asker
Tel: +47 66 75 34 00
parker.norway@parker.com

PL – Poland, Warsaw
Tel: +48 (0)22 573 24 00
parker.poland@parker.com

PT – Portugal, Leca da Palmeira
Tel: +351 22 999 7360
parker.portugal@parker.com

RO – Romania, Bucharest
Tel: +40 21 252 1382
parker.romania@parker.com

RU – Russia, Moscow
Tel: +7 495 645-2156
parker.russia@parker.com

SE – Sweden, Spånga
Tel: +46 (0)8 59 79 50 00
parker.sweden@parker.com

SK – Slovakia, Banská Bystrica
Tel: +421 484 162 252
parker.slovakia@parker.com

SL – Slovenia, Novo Mesto
Tel: +386 7 337 6650
parker.slovenia@parker.com

TR – Turkey, Istanbul
Tel: +90 216 4997081
parker.turkey@parker.com

UA – Ukraine, Kiev
Tel: +380 44 494 2731
parker.ukraine@parker.com

UK – United Kingdom, Warwick
Tel: +44 (0)1926 317 878
parker.uk@parker.com

ZA – South Africa, Kempton Park
Tel: +27 (0)11 961 0700
parker.southafrica@parker.com

North America

CA – Canada, Milton, Ontario
Tel: +1 905 693 3000

US – USA, Cleveland
Tel: +1 216 896 3000

Asia Pacific

AU – Australia, Castle Hill
Tel: +61 (0)2-9634 7777

CN – China, Shanghai
Tel: +86 21 2899 5000

HK – Hong Kong
Tel: +852 2428 8008

IN – India, Mumbai
Tel: +91 22 6513 7081-85

JP – Japan, Tokyo
Tel: +81 (0)3 6408 3901

KR – South Korea, Seoul
Tel: +82 2 559 0400

MY – Malaysia, Shah Alam
Tel: +60 3 7849 0800

NZ – New Zealand, Mt Wellington
Tel: +64 9 574 1744

SG – Singapore
Tel: +65 6887 6300

TH – Thailand, Bangkok
Tel: +662 717 8140

TW – Taiwan, Taipei
Tel: +886 2 2298 8987

South America

AR – Argentina, Buenos Aires
Tel: +54 3327 44 4129

BR – Brazil, Sao Jose dos Campos
Tel: +55 12 4009 3500

CL – Chile, Santiago
Tel: +56 2 623 1216

MX – Mexico, Apodaca
Tel: +52 81 8156 6000

VE – Venezuela, Caracas
Tel: +58 212 238 5422

European Product Information Centre

Free phone: 00 800 27 27 5374

(from AT, BE, CH, CZ, DE, DK, EE, ES, FI,
FR, IE, IL, IS, IT, LU, MT, NL, NO, PL, PT, RU,
SE, SK, UK, ZA)



Fluid System Connectors Europe

Legris SAS

Parker Hannifin Corporation

CS 46911 - 74 rue de Paris

35069 Rennes

phone : +33 (0)2 99 25 55 00

fax : +33 (0)2 99 25 55 99

www.parkerconnectic.com