



SPRING BALANCER

ENDO "SPRING BALANCER" SERIES



CERT No.Q10458



ENDO
ENDO KOGYO CO.,LTD.

ENDO SPRING BALANCERS

What is Spring balancers?

The tension is kept stable on even if the cable is pulled out or retrieved because of the tapered drum. So Spring balancers can hold the tools suspended in hollow and work for flexible positioning of the tools. Workers can enjoy comfortable operation with less fatigue.

ENDO Spring balancers can play their active parts in;

- Suspending a tool for product assembly line.
- Frequent fastening screws, bolts and nuts.
- Suspending a jig, tool, welding gun etc.

Advantage

- The balancers improve working efficiency and diminish worker fatigue.
- The balancers make the position of a tool stable and contribute to accurate work.
- The balancers are available for keeping a tool clean.
- Any electric or pneumatic power is not required and safe working is achieved.

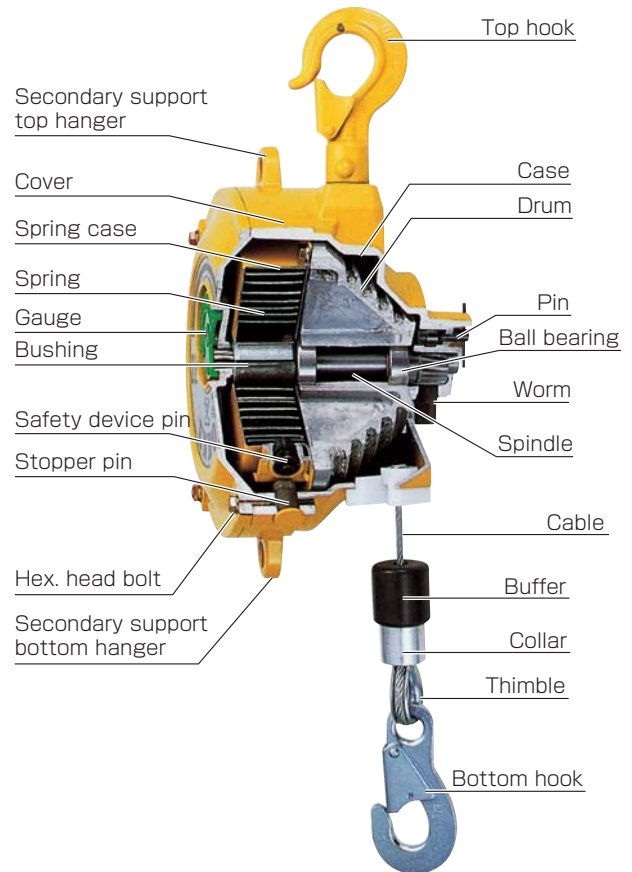

Features

* All features are not always available on all balancers.



Fall arrest devices

The fall arrest device is provided against tool drop caused by spring breakage.



Secondary support hanger

The secondary support hanger is available on every model.

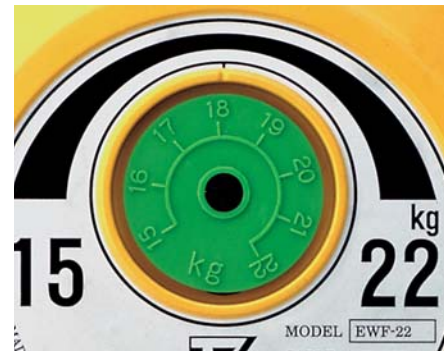

Gauge

The gauge indication contributes to worker recognition on tension adjustment.



Drum lock system

Drum lock is available for easy tool or cable replacement.



Cartridge spring

Cartridge spring provides easy and safe spring replacement.



Wire rope replacement

The plug fixing system provides the easy cable replacement.

Selection of suitable model

Always use a suitable model meeting the total weight of suspended tool or instrument. The balancer should be selected considering the weight of the tool and accessories. (Example)

1. The weight of a tool (assuming that it is 14kg) + the weight of accessories (3kg) is equal to 17kg (Total weight). EWF-22 or ELB-22 (15 to 22kg) is suitable for the application.
2. If the total weight is on the border of models, please select larger model. It will provide longer spring life.

The tool weight (19kg) + the accessories weight (3kg) = 22kg. EWF-30 (22kg to 30kg) should be selected. If the fall arrest system works at the situation, please add an additional weight to recover the system.

Installation

- Install Spring balancers uneven not to hit each other when the balancers are installed in a line.
- Always employ a secondary support chain and leave the slack for smooth swivel.
- Always adjust the spring tension to meet the total weight of tool and the application.

Spring tension adjustment

Worm gear system, Ratchet system or Handle system are available and dependent on the models. Clockwise adjustment increases the spring tension and Counter clockwise adjustment decreases the spring tension. (The spring tension has been set at the middle of capacity in advance prior to shipment)

Handle system	ERP model				
Ratchet system	EK-00,EK-0	EW-3 & 5		ER model	ATB model
Worm gear system	EWS model	EWF model	ELF model	RSB model	
	ETP model	THB model	ATR model	EWA model	

Handle system



Worm gear system

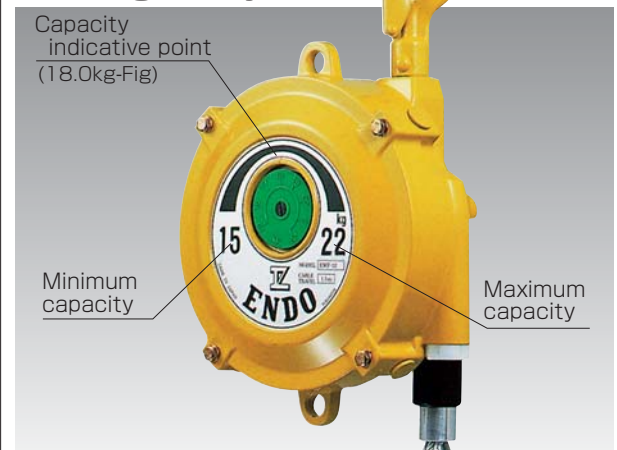

Ratchet system

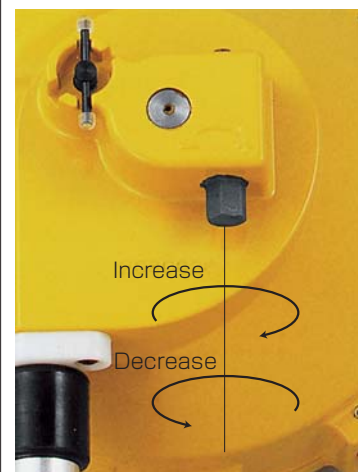
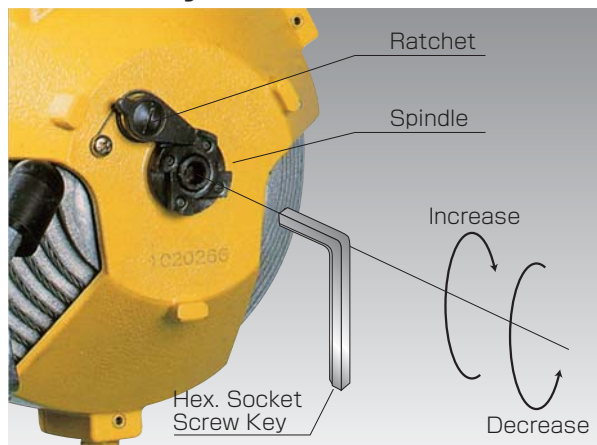

Read the instruction manual carefully for details.

Summary

Type	Model	Capacity (kg)	Stroke (m)	Cable dia (φ mm)	Mass (kg)	
Light capacity	EK-00	0.5~ 1.5	0.5	2.0	0.2	They are suitable for the light weight tool like an electric driver.
	EK-0	0.5~ 1.5	1.0	3.0	0.5	
	ERP-06E	0.3~ 0.6	1.5	1.2	0.4	
	ERP-1E	0.5~ 1.0	1.5	1.2	0.4	
	ERP-2E	1.0~ 2.0	1.5	1.2	0.4	
Standard	EW-3	1.0~ 3.0	1.3	3.0	1.4	Many safety features are equipped and they are most popular. For a welding gun, Pneumatic tool etc.
	EW-5	2.5~ 5.0	1.3	3.0	1.5	
	EWS-3	1.5~ 3.0	1.3	3.0	1.9	
	EWS-5	3.0~ 5.0	1.3	3.0	2.1	
	EWS-7	5.0~ 7.0	1.3	3.0	2.1	
	EFW-9	4.5~ 9.0	1.3	4.0	3.5	
	EFW-15	9.0~ 15.0	1.3	4.0	3.8	
	EFW-22	15.0~ 22.0	1.5	4.76	7.3	
	EFW-30	22.0~ 30.0	1.5	4.76	7.7	
	EFW-40	30.0~ 40.0	1.5	4.76	9.7	
	EFW-50	40.0~ 50.0	1.5	4.76	10.1	
	EFW-60	50.0~ 60.0	1.5	4.76	11.1	
Large capacity	EFW-70	60.0~ 70.0	1.5	4.76	11.4	They are suitable for a heavy weight device like multiple nut runner. The special balancers engineered for the top hook replacement without dismantling are available for EWF-90 to EWF-120 on request. The model names are changed to EWF-90A, EWF-105A and EWF-120A respectively.
	EFW-90	70.0~ 90.0	2.0	4.76	21.9	
	EFW-105	85.0~105.0	2.0	4.76	24.0	
	EFW-120	100.0~120.0	2.0	4.76	27.5	
	ETP-14	120.0~140.0	1.2	6.0	24.1	
	ETP-15	140.0~170.0	1.2	6.0	28.7	
Long stroke	ETP-16	170.0~200.0	1.2	6.0	29.7	They are available for high ceiling application.
	ELF-3	1.5~ 3.0	2.5	3.0	4.6	
	ELF-5	3.0~ 5.0	2.5	3.0	4.8	
	ELF-9	5.0~ 9.0	2.5	3.0	5.4	
	ELF-15	9.0~ 15.0	2.5	4.76	10.0	
	ELF-22	15.0~ 22.0	2.5	4.76	10.2	
	ELF-30	22.0~ 30.0	2.5	4.76	11.0	
	ELF-40	30.0~ 40.0	2.5	4.76	14.0	
	ELF-50	40.0~ 50.0	2.5	4.76	14.5	
	ELF-60	50.0~ 60.0	2.5	4.76	17.1	
With Ratchet	ELF-70	60.0~ 70.0	2.5	4.76	18.0	They are available for holding the suspended tool on the way of stroke mechanically. Even if no load is applied, the balancer can hold the hook on the way of stroke.
	RSB-15	9.0~ 15.0	1.5	5.0	7.4	
	RSB-22	15.0~ 22.0	1.5	5.0	7.7	
	RSB-30	22.0~ 30.0	1.5	5.0	8.1	
	RSB-40	30.0~ 40.0	1.5	5.0	8.5	

Definition of Mark



Gauge

Easy indication of spring tension.



Plug type cable set

Cable replacement without dismantle.



Cartridge spring assembly

Safe and easy spring replacement.



Drum lock device

Easy tool replacement.



Ratchet device

Mechanical hug of hook on stroke.



Fall arrest device

Tool fall protection against spring breakage.



Snap back protection

Protection against sudden cable snap back caused by cable cut or tool detachment.



Handle system spring adjustment

The tension is adjusted without any tool.



Cushion cover available

The cushion is available for case protection.



Worm gear spring adjustment

The system provides safe tension adjustment due to worm gear feature.



Ratchet system spring adjustment

Mainly the device is equipped with small balancers.



CE Mark available

EK-00

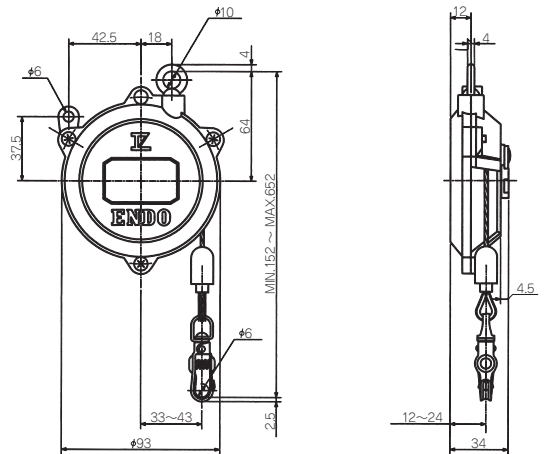

EK-0

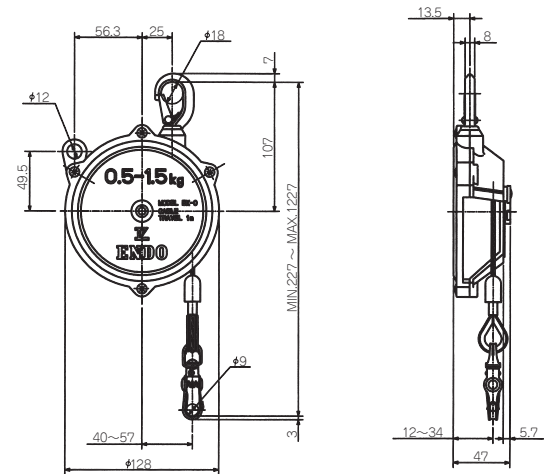

ERP-06·1·2

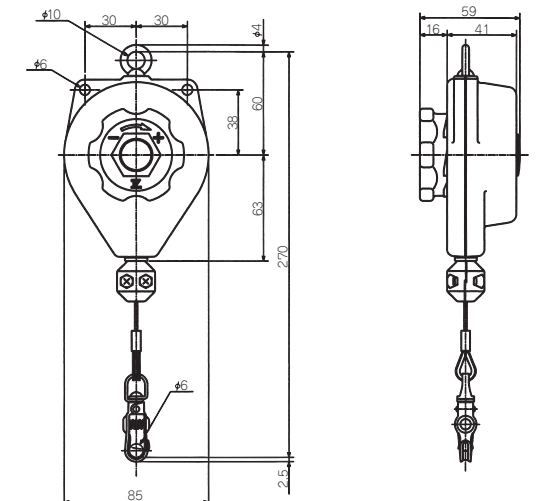

* A nylon rope is employed for CE market instead of a nylon coated cable.

EW-3·5



* Only EW-3 is available for CE Mark.

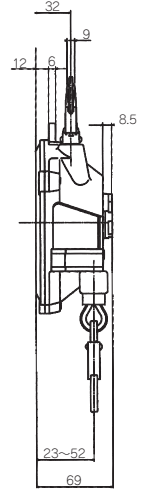
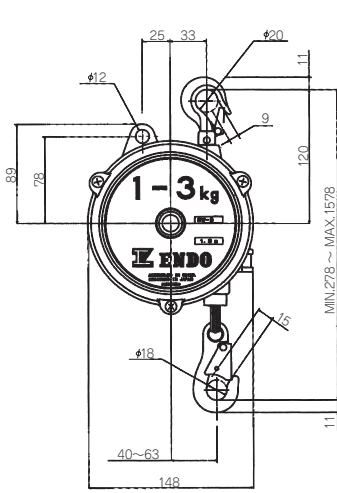

EWS-3·5·7

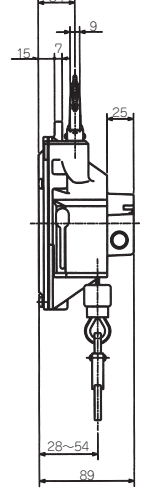
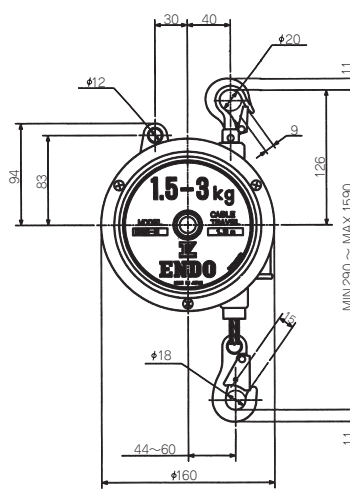

EFW-9·15

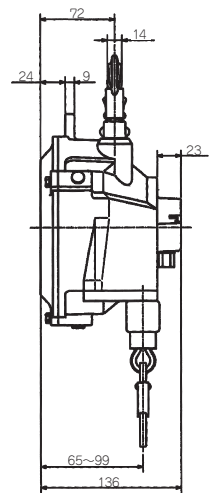
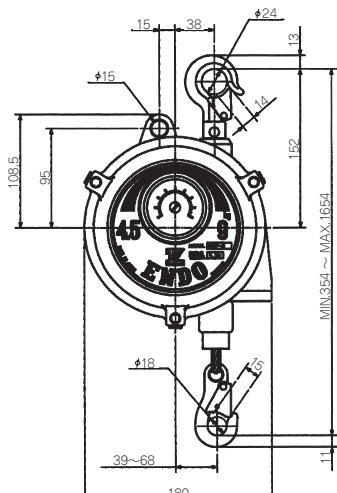
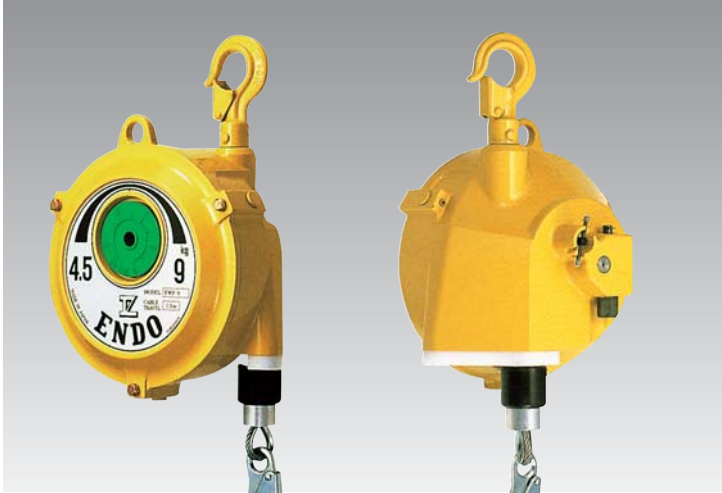

EWF-22·30

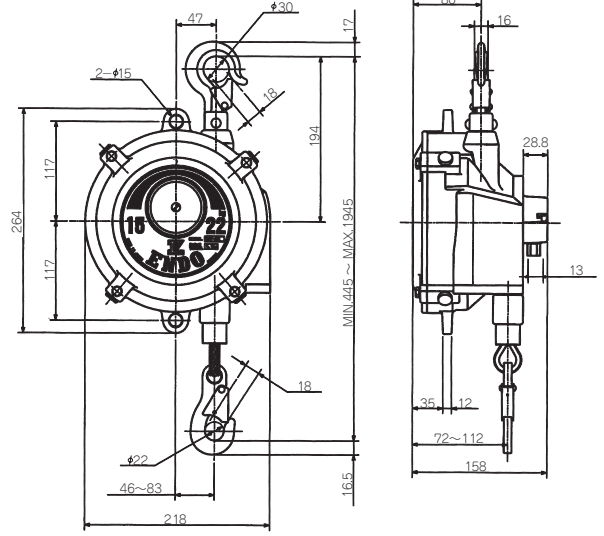

EWF-40·50·60·70

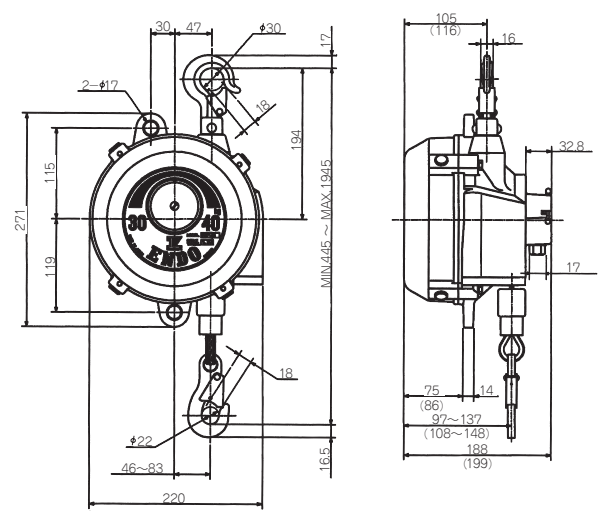

* () dimension shows EWF-60~70.

EWF-90·105·120

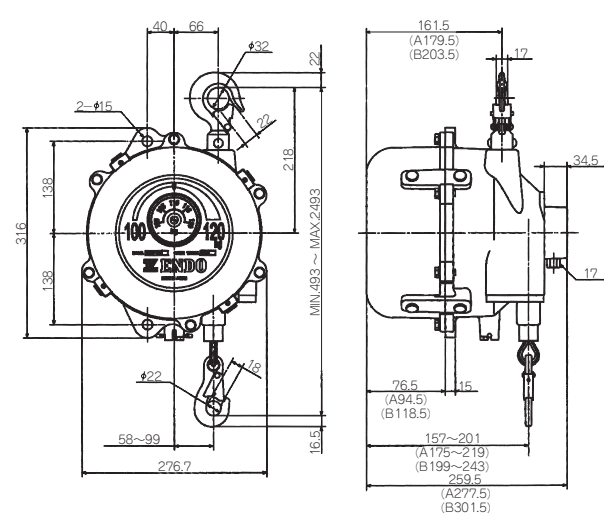

* () dimension A shows EWF-105, B shows EWF-120.

EWF-90A·105A·120A

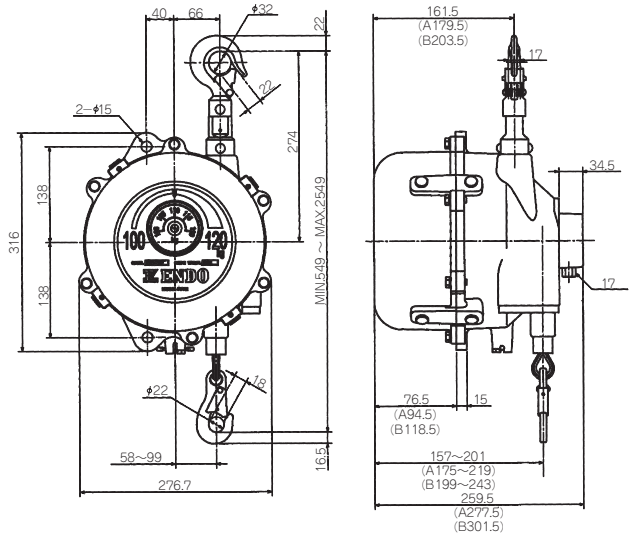

* () dimension A shows EWF-105A, B shows EWF-120A.

ETP-14·15·16

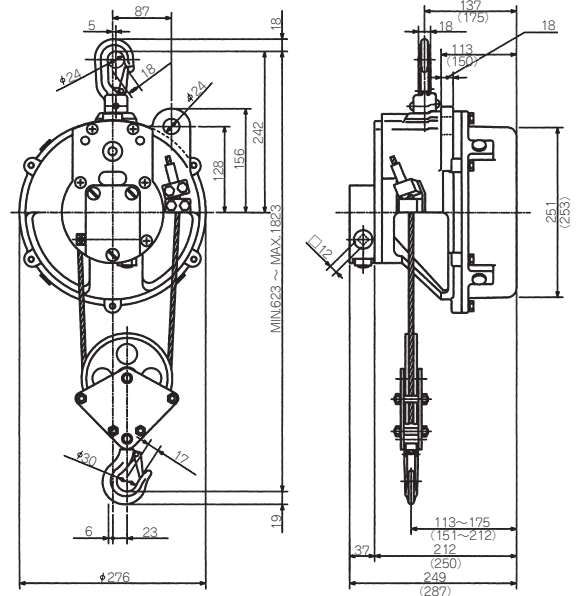

* () dimension shows ETP-15~16.

ELF-3·5·9

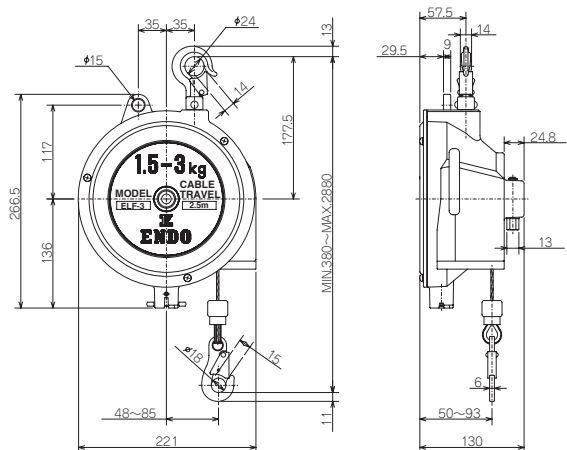

Torque reel

This model with a long cable travel is suitable for hanging pendant switch and so on because of its ratchet system.

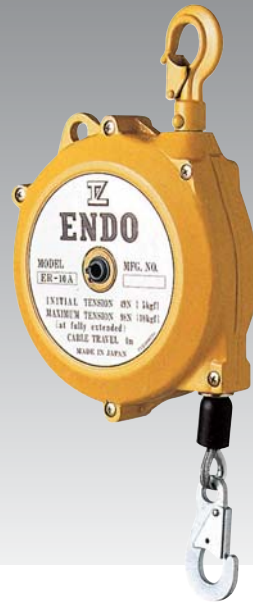

Features

This can be stopped on the way of cable travel because of ratchet system. (ER-3A, ER-5A, ER-10A)

The jamming of the cable will not occur because of its cylindrical drum.

They has long cable travel (ER-3A·3B, 5A·5B = 3m, ER-10A·10B = 4m) and are designed light and compact.

Model	Initial Max. tension (tension at retracted)		Active cable travel (m)	Tension build-up, full length of cable		the number of available spring winding	with or without ratchet	Diameter of cable (φ mm)	Mass (kg)
	N	{kgf}		N	{kgf}				
ER-3A	18	1.8	3	12	1.2	about 16	with	2.38	1.4
ER-3B	18	1.8	3	12	1.2	about 16	without	2.38	1.3
ER-5A	25	2.5	3	25	2.5	about 13	with	2.38	1.5
ER-5B	25	2.5	3	25	2.5	about 13	without	2.38	1.4
ER-10A	49	5.0	4	49	5.0	about 13	with	2.38	4.5
ER-10B	49	5.0	4	49	5.0	about 13	without	2.38	3.8

(note) The tension increases gradually as the cable is pulled out. For example, on ER-5A, supporting that the tension of spring is adjusted at 25N {2.5kgf} when the cable is fully retracted, the tension of spring (when the cable is pulled out 3m) is equal to 50N (25+25) {2.5+2.5=5kgf}

Tension curves

● The relation with the number of drum revolving and the length of winding cable

The length of winding cable per one revolving of drum

ER-3A·3B·5A·5B.....about 350mm
ER-10A·10B.....about 480mm

ER-3A·3B

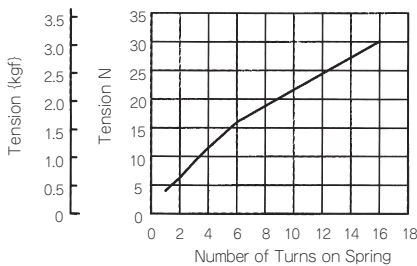

ER-5A·5B

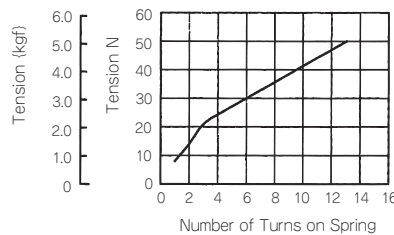

ER-10A·10B

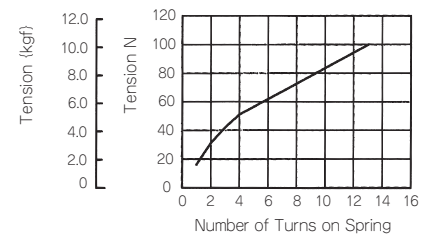

■ Dimensions (mm)

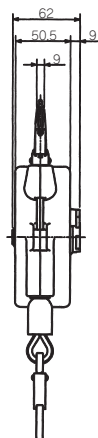

ER-3A·3B·5A·5B

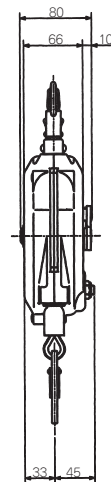
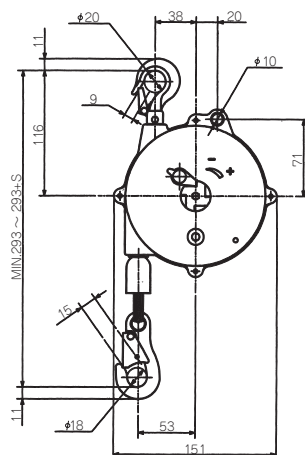

ER-10A·10B

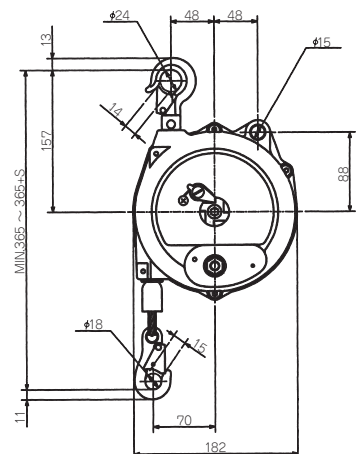

Air tool balancer

This model has the function of both hose reel and balancer.

This one is suitable for hanging the air tool and so on, and the hose is arranged in order.

Structure · Characteristic

Instead of the cable of balancer, the urethane hose is wound. So to speak, hose reel has the function of balancer. Air tools can be easily moved up and down.

Casing and drum are made of acrylonitrile-butadiene-styrene resin and they are light.

Hose is the urethane hose. Always keep it away from fire.

The diameter of hose nipple is $\phi 9$ at inlet portion, and swivel joint size Rc, 1/4 at outlet portion.

Model	Capacity (kg)	Hose travel (m)	Air inlet. (ϕ mm)	Mass (kg)
ATB-0	0.5~1.5	1.3	6.3	1.58
ATB-1	1.5~3.0	1.3	6.3	1.66
ATB-2	3.0~5.0	1.3	6.3	1.73

※ATB-2 is not available for CE mark.

Flow characteristics

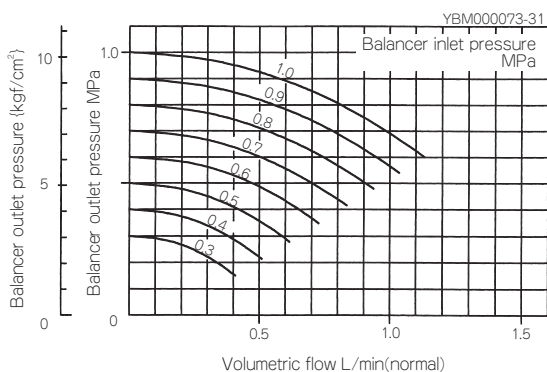

■Dimensions (mm)

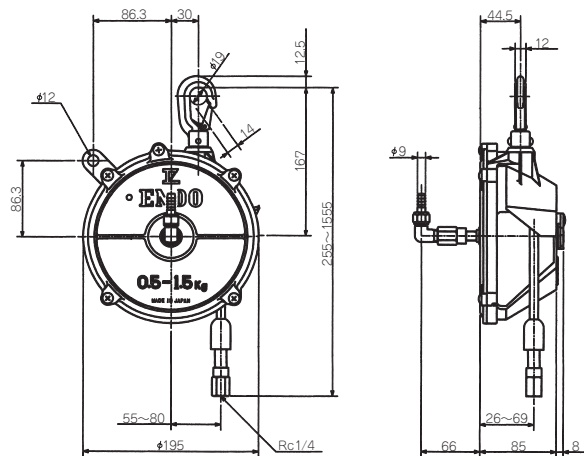

Accessories

Protect wire set

Product number Available model

LBP000794a ATB-0, 1, 2

The protector is available for tool fall protection caused by unintentionally detaching an air tool from a coupling.



Tool hose balancers

Features

When the spring failure is happened, the fall prevention device will operate and stop the suspended tool / device.

The inside diameter of hose is $\phi 8.5$ which supplies enough air to operate the suspended air tool / device.

Working conditions

- Application area : Indoor and normal atmospheric conditions
- Temperature rang : -10°C to $+40^{\circ}\text{C}$
- Application fluid : Air
- Maximum air pressure : 1.0MPa {10kgf/cm²}

Model	Capacity (kg)	Hose travel (m)	Hose inside diameter. (ϕ mm)	Mass (kg)
THB-15	0.5~1.5	1.3	8.5	1.9
THB-25	1.5~2.5	1.3	8.5	2.0
THB-35	2.5~3.5	1.3	8.5	2.1
THB-50	3.5~5.0	1.3	8.5	2.1
THB-65	5.0~6.5	1.3	8.5	2.2

Flow characteristics

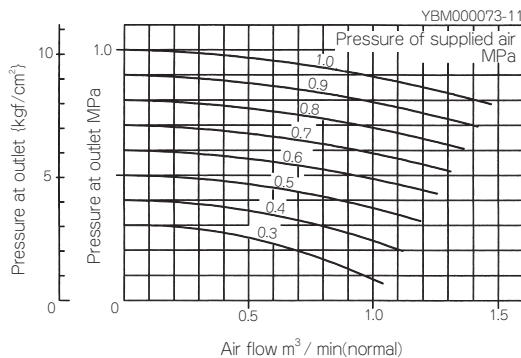

Special accessories

Swivel elbow fitting for air inlet. (outer dia 10.5mm)

Parts No.

LBP000654

Swivel Joint.

Parts No.

LBP000659

Protect wire.

Parts No.

LBP000801

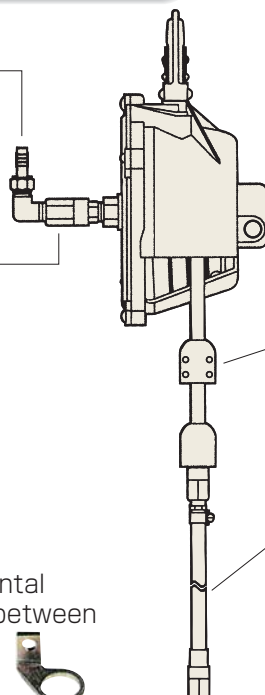
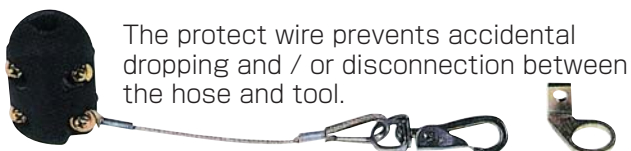

Coupling socket (Outer dia 11.3mm)

Parts No.

LBP000784



Adjustable hose stopper.

Parts No.

LBP000800

A special hose for an extended length. (with a swivel joint ; 1m)

Parts No.

LBP000785

(max. 2m extension)



Dimensions (mm)

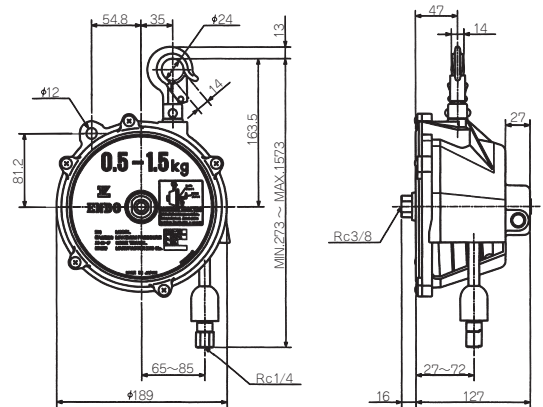

Air tool reel

Features

An included spring works to retract a hose into the device automatically.

A contained hose solves the short of air consumption for air tool owing to a large inner diameter of 10φ.

A ratchet system applied for the device can keep a tool suspended at any position on the hose travel where you want.

※On-off work of ratchet system is available through knob operation.

The fall preventive system from the tool drop works when the included spring has been broken.

You can adjust the spring tension using a warm adjustable system.

An enclosed swivel joint contributes to easy installation.



Model	Max tension N {kgf}	Hose travel (m)	Air inlet. (φmm)	Mass (kg)
ATR-5	4.9 {5.0}	2.0	10.0	3.8
ATR-5-1	4.9 {5.0}	2.0	10.0	4.2

Accessories



A special hose for extended length. (with a swivel joint)



Adjustable hose stopper.

Type	Parts No.
1m	LBP000663
2m	LBP000664
3m	LBP000665

Parts No.
LRP007933

Flow characteristics

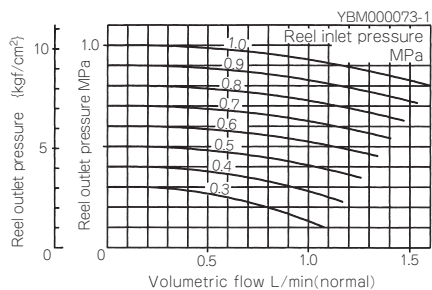

Tension curves

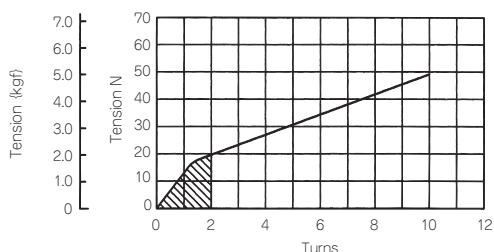

Dimensions (mm)

ATR-5

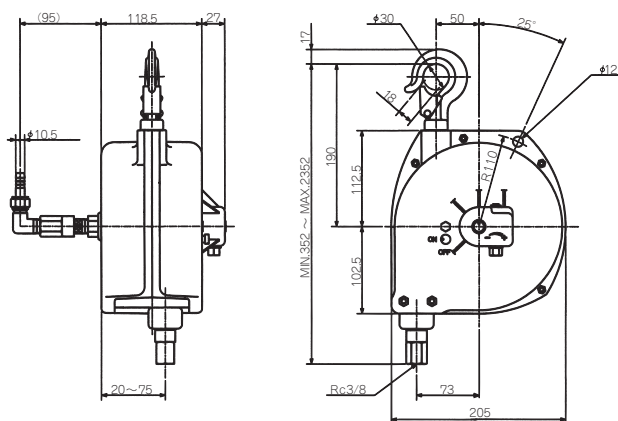

ATR-5-1

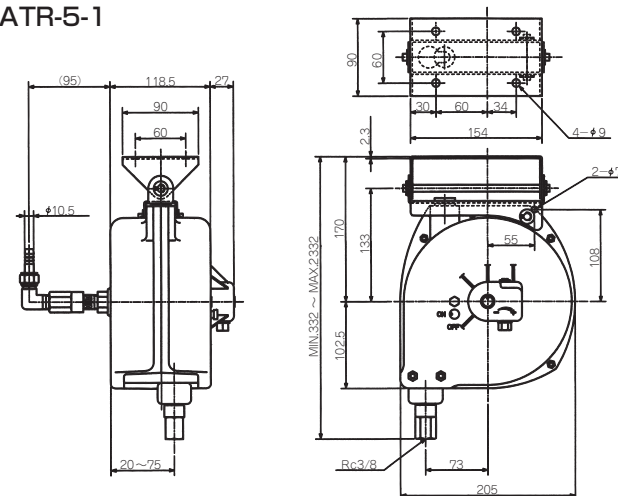

Cushion

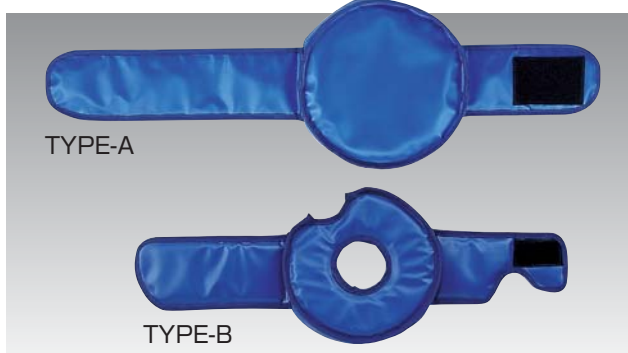

TYPE-A

P2B300789

TYPE-B

P2B300799



Insulation Hook



Parts No.	Diameter of cable (φmm)	Available model
LBP000145b	4	EFW-9·15
LBP000146a	4.76	EFW-22~70, EWA-22~70
LBP001185	4.76	EFW-90~120, EWF-90A~120A

Owing to insulation of holder, it becomes unnecessary to use the insulation made of ceramic (or others) which is casual at present. This composes one set with special cable.



Adjustable cable stopper

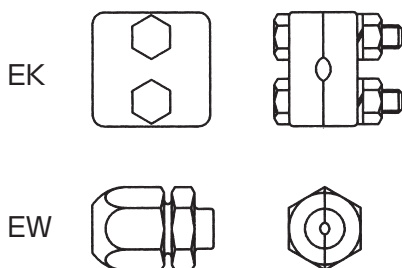

Name	Parts No.	Available model
EK Stopper	LBP000127	RSB-15~40
EK Stopper	LBP000150	ER-3A·3B~10A·10B
EW Stopper	LBP000130	EW-3~5, ELF-3·5·9
EW Stopper	LBP000131	EFW-9~15
EW Stopper	LBP000132	EFW-22~70, ELF-15~70 EFW-90~120, EWF-90A~120A

Karabina

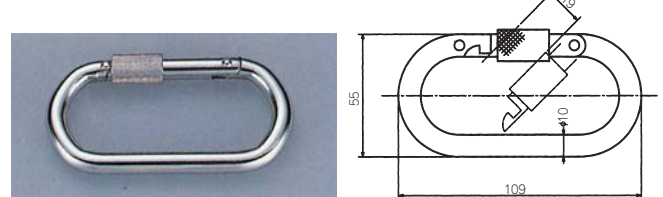

Parts No.

P2S400104a

Breaking load

16.7kN {1700kgf}

S Type hook

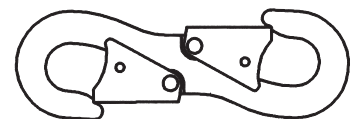

Model	Parts No.	Working load	Mass(kg)
SH-60	LBP000231	590N {60kgf}	0.16
SH-150	LBP000232	1470N {150kgf}	0.43

Corresponding table of Accessories

Parts No.	Name		EW 3・5	EWS	EFW 9・15	EFW 22~70	EFW 90~120	EWA	ELF 3~9	ELF 15~70	ER	RSB	ATB	THB	ATR
LBP000145b	Insulator hook	φ4.0			○										
LBP000146a	Insulation hook	φ4.76				○		○							
LBP001185	Insulator hook	φ4.76					○								
LBP000127	stopper	EK										○			
LBP000150	stopper	EK									○				
LBP000130	stopper	EW	○	○					○						
LBP000131	stopper	EW			○										
LBP000132	stopper	EW				○	○	○		○					
LBP000800a	stopper	THB												○	
LRP007993	stopper	ATR													○
P2B300789	cushion	TYPE-A				○		○							
P2B300799	cushion	TYPE-B											○	○	
P2S400104a	karabina		○	○	○	○		○	○	○		○	○	○	○
LBP000794a	protect wire	ATB											○		
LBP000801	protect wire	THB												○	
LBP000784	Quick coupler													○	
LBP000654	union elbow													○	
LBP000659	Swivel joint													○	
LBP000785	Extension hose	1m												○	
LBP000786	Extension hose	2m												○	
LBP000663	Extension hose	1m													○
LBP000664	Extension hose	2m													○
LBP000665	Extension hose	3m													○



ENDO KOGYO CO., LTD.

Head Office 3-14-7, Akibacho, Tsubame, Niigata, Japan
TEL.0256-62-5131 FAX.0256-62-5772

Tokyo Office Tanaka Bldg., 2F.12, Kanda Higashimatushita-cho, Chiyodaku, Tokyo, Japan
TEL.03-5295-3711 FAX.03-5295-3717

Osaka Office Daito Bldg., 3F, 3-14, Saiwaicho 2-chome, Naniwaku, Osaka, Japan
TEL.06-6568-1571 FAX.06-6568-1573

Kyusyu Office Bunki Bldg., 3F.11-15, Hakataekihigashi 3-chome, Hakataku, Fukuoka, Japan
TEL.092-412-5281 FAX.092-412-5280

URL <http://www.endo-kogyo.co.jp>

※Items shown in this catalogue are subject to change without notice.

※Please note we do not have responsibility for missing and fault on the printing.

EC-68B 2008.04.3000®